

EM 5½" FASCIA GUTTER Seamless Gutter Machine

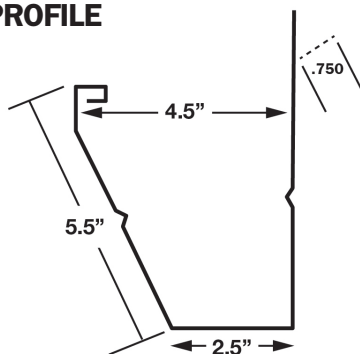

Every gutter company needs an EM 5½" Fascia Gutter Machine for those gutter jobs that do not have fascia installed. Our 5½" fascia gutter machine features unique and fully driven forming stations that are enclosed with a steel cover to protect the operators and keep the roll-former free and clear of debris. All bearings are factory-sealed. Eastside fascia gutter machines are driven by a powerful 1.5HP, 110-volt single phase motor and is constructed of heavy gauge steel. The EM 5½" Fascia Gutter machine is completely enclosed, and has removable side panels for easily serviceability. The machine is powder-coated inside and out with a heavy-duty industrial paint finish for protection and features industrial nitrocarburized (QPQ) steel rollers. Nitrocarburizing rollers allow for improved wear, lubricity, strength and corrosion resistance.

PROFILE



GET MORE INFO



info@eastsidemachine.com
TOLL-FREE (800) 234-7834
www.eastsidemachine.com

(701) 237-5952 | FAX (701) 232-6666
474 45th St S, Fargo, ND 58103
PO Box 2426, Fargo, ND 58108-2426

STANDARD PACKAGE

- 1 5½" Fascia Gutter Machine
- 2 Coil Spool Assemblies with Turntables
- 1 Guillotine Cutter
- 3 Run-Out Stands

FEATURES

- Fully driven forming stations
- Factory-sealed bearings
- Unique forming process
- Enclosed forming
- Industrial nitrocarburized rollers
- Pencil bead (or optional 3/4" wide bead)

INCLUDES

- Operational training and technical support
- 2-year warranty

SPECIFICATIONS

DIMENSIONS

LENGTH 18'
WIDTH 23"
HEIGHT 55"

WEIGHT 1370 lbs
(2170 lbs with 2 turntables and coil spool mounts)

COIL WIDTH 14" and 15"
(Options available upon request)

MATERIAL

STEEL 26 - 29 gauge
ALUMINUM 0.024 - 0.032
COPPER 16 or 20 oz

POWER 1.5HP, 110V,
Single Phase, 18A

SPEED Approx 36 ft/min

FORMING STATIONS 12

SHEAR/CUTTER Side Pull
Guillotine

CONTROLS Drumswitch at
exit end with Jog/Run